



# **Durango Fire & Rescue**

## **Company Performance Tasks (CPT's)**

Version 11.10  
NOVEMBER, 2011

# Company Performance Tasks (CPT's)

## Introduction

**CPT's are designed to deliver standard training on specific tasks that can be applied on the fireground or other emergency scenes. They are designed to be flexible so that they can be adapted to differing training environments, and limited in scope so they can be linked to provide multi-company drills. Each CPT will state the recommended number of personnel to complete the drill, but any number of available personnel can be used.**

All CPT's have a timing component. The purpose of timing these drills is to measure success and find ways to increase efficiency without sacrificing safety. Variations in the training environment-location, weather, and number of personnel-will all have an impact on the time an evolution takes. Consider the advantage of doing a CPT 3 or 4 times and finding each time that the company is able to shave a few seconds or minutes and perhaps find new or better ways to handle a given situation.

The CPT's are broken down into the following categories:

- 1 General
- 2 Engine Company Operations
- 3 Ladder Company Operations
- 4 Special Operations
- 5 Water Supply Operations

CPT's are drills that stress mastery of the skill through repetition. After each CPT is a Training Outline to aid instruction. In the back of this book is a glossary of terms that helps to explain important concepts.

NFPA 1410 *Standard on Training for Initial Emergency Scene Operations* provides the basis for some of these drills. Others were provided to us courtesy of South Metro Fire Rescue Authority. DFRA has also constructed drills. In all cases the drills have been modified to fit DFRA's needs and are not meant to represent any single industry standard.

Each CPT can be broken into individual components if there are not sufficient personnel available to meet the minimum requirement.

# Company Performance Tasks (CPT's)

## Table of Contents

### **1. General**

- 1.1 SCBA-Team Donning with Simulated response
- 1.2 Positive pressure Attack (PPA)

### **2. Engine Company Operations**

- 2.1 One 1 ¾" line without water supply
- 2.2 Two 1 ¾" lines with Hydrant supply
- 2.3 2 ½" to gated wye to hose packs
- 2.4 Deploying a Portable Monitor
- 2.5 Two 2 ½" lines with Hydrant Supply

### **3. Ladder Company Operations**

- 3.1 Single FF Ladder Raise-14', 16', and 24'
- 3.2 Two FF Ladder Raise-24' and 28'
- 3.3 Three FF Ladder Raise-35'
- 3.4 Vertical Ventilation

### **4. Special Operations**

- 4.1 Low Angle Lowering and Raising System with Belay
- 4.2 Low Angle Patient Packaging with Attendants
- 4.3 Vehicle Extrication-Stabilization
- 4.4 Vehicle Extrication-Portable & Fixed Hydraulic Power Units
- 4.5 Haz-Mat Air Monitoring

### **5. Water Supply operations**

- 5.1 Fill Site Operations
- 5.2 Dump Site operations

### **6. Wildland fire operations**

- 6.1 Wildland Shelter Deployment
- 6.2 Wildfire line construction and systematic mop up
- 6.3 Wildfire Progressive hose lay

**Instructions:** This evolution simulates one crew's effort to ready themselves to enter an IDLH environment. The drill uses 1 company with a minimum of 2 members wearing full PPE. Time starts when the first person steps off the apparatus. Time will stop when the firefighters are breathing air and prepared for entry. Two members must be on the line at completion.

**Given:** Any Fire apparatus with crew of two or more.

**Conditions:**

- 1) Evolutions should be executed at normal working speed with proper consideration for safety.
- 2) The officer will call out and control all evolutions.
- 3) Recommended time: 2 minutes.

**Critical Criteria:**

- 1) PPE worn correctly, facepiece in place, no visible skin, and cylinder fully on.
- 2) Buddy or READY check performed
- 3) Crew will have all appropriate hand tools, box lights, TIC, etc. as necessary for entry.
- 4) Proper size up accomplished prior to entry.

**Drill:**

1. Don PPE, get in apparatus, don SCBA and seatbelt before moving.
2. Wait for air brake to set, and exit apparatus without facepiece in place.
3. Receive assignment(s) from Officer.
4. Gather tools for entry based on assignment.
5. Mentally size-up structure.
6. Gather team at entry door, prepare for entry.
7. Perform Buddy or *READY* check.
8. Enter structure as a team.

**Alternate drill:**

In place of step one and two above, go from the ground (recruit class style), or from standing next to the unit – pulling it from the compartment or the jump seat, and putting it in service while standing (I went to the unit to get an SCBA style).

## I. Pre-arrival

A. Don appropriate PPE prior to leaving the station. It is easier and safer to dress before responding on an apparatus.

B. Attempt to don SCBA prior to responding. Again, it is easier and safer.

C. Communicate to the Operator that you are securely belted and ready to go.

D. While responding size up the incident based on:

Dispatch information

Type of call

Type of structure

Time of day

Weather

Other information such as access, water supply, number of responding units, etc

## II. Arrival

A. Initial size up and radio report

B. 360° size up

C. Determine priorities

1. Strategic

Life safety

Incident stabilization

Property conservation

2. Tactical

Rescue

Exposures

Confine

Extinguish

Overhaul

Ventilate

Salvage

Rescue

Exposures

Ventilation

Attack

Salvage

D. Determine mode of operation

1. Offensive

a. Do we go interior?

b. Equipment

Box lights

Hand tools

Irons for forcible entry

Pike pole to check overhead

Sledgehammer for forcing commercial doors

2. Buddy check complete?

a. Traditional

b. READY check

Radio

Equipment

Air

Duties

Yes!

E. Entry

**Instructions:** This evolution simulates a residential positive pressure attack with a single 1 ¾" line off of tank water. If personnel permit, a hydrant or other water source may be utilized. The drill uses 1 company with a minimum of 3 members wearing full PPE. Time starts when the first person steps off the apparatus. Time will stop when the air is bled from the hose, nozzle pattern is set, fan is blowing sufficient air with sufficient exhaust openings so that no pressurized smoke is coming from the entrance point, and firefighters are breathing air and prepared for entry. Two members must be on the line at completion.

**Given:** Any Fire apparatus with crew of three or more.

**Conditions:**

- 1) Evolutions should be executed at normal working speed with proper consideration for safety.
- 2) The officer will call out and control all evolutions.
- 3) Recommended time: 4 minutes.

**Critical Criteria:**

- 1) PPE worn correctly, facepiece in place, no visible skin, and cylinder fully on.
- 2) Buddy or READY check performed.
- 3) Crew will have all appropriate hand tools, box lights, TIC, etc. as necessary for entry.
- 4) Proper size up accomplished prior to entry.

**Drill:**

1. Officer: Sizes up the fire and determines that PPA can be used, making or improving the exhaust opening prior to pressurization. The officer then joins the attack crew as it enters the building.
2. Nozzle: Deploys the attack line to the area as directed by the officer.
3. Fan/Hydrant: If this position does not take a hydrant, this person is responsible for taking forcible entry tools and the blower to the attack entrance.
4. Driver Operator: Operates the pump and assists with hoseline deployment as necessary.

For example, if you tried PPA with three firefighters, the officer would take the fan from the engine on his way to the building, drop it off near the attack entrance, then continue with the exhaust. The nozzle firefighter would then deploy the hoseline and carry forcible entry tools to the attack entrance. The driver-operator could assist with either of these two functions.

**Three precautions:**

First, start pressurization as the initial attack crew enters. You cannot have crews inside the building and then put a fan at their back. You cannot account for their whereabouts or the conditions between the fan and the crew and you may cause them harm.

Second, train and educate yourself regarding PPA prior to starting to implement it. Knowing how to start a fan and not accounting for any of the other conditions will injure or kill firefighters. PPA is a dramatic attack tool that is terrific when used correctly, but is also one that, when used inappropriately, can cause things to get worse.

Third, you need ample exhaust ahead of the firefighters. If smoke and fire come back towards the attack crew, you do not have enough exhaust and have not controlled the environment by directing away from your crews; you are just going through the motions. Adjust and continue the attack only when you can see and clear the building of fire as you advance towards the seat of the fire.

**This is the sequence of taking out windows:**

First, take out a window in the area that you assume to be closest to the fire. Most of the time fire will be showing, so this is not a big deal. However, if it is not obvious, take your best guess and see if that window starts to exhaust a heavy volume of smoke and fire. If it does not, take your next best guess. If you still do not get heavy products of combustion and there is a sublevel, open one of those windows to make sure you are not entering an area that may be unsafe. If you still do not get a heavy volume exhausting, check the floor above on your way to the attic area. A thermal imaging camera may be of some help if one is handy and will not delay the attack. If any of the windows mentioned above yield a heavy volume of fire and smoke, open adjacent windows on each side of that one with the idea being that you are clearing additional rooms.

As always, the exhaust opening should start at two to three times the size of the entrance and then be adjusted based upon fire conditions. If fire and smoke are still exhausting with high levels of pressure, you could still use additional openings. If fire and smoke are returning to the attack entrance and trying to exhaust over the top of the blower, you could still use more exhaust openings. If the interior environment is clearing and crews are making continual progress throughout the structure, your exhaust is adequate.

If crews are not making continual progress and fire conditions are not allowing them to advance for more than five minutes, give strong consideration to evacuating the building until conditions can be improved with additional crews or better ventilation.

**Instructions:** This evolution simulates a residential fire attack with a single 1 3/4" line off of tank water. The drill uses 1 company with a minimum of 3 members wearing full PPE. Time starts when the first person steps off the apparatus. Time will stop when the air is bled from the hose, nozzle pattern is set and firefighters are breathing air and prepared for entry. Two members must be on the line at completion.

**Given:** Pumping apparatus with crew of three.

**Conditions:**

- 1) Evolutions should be executed at normal working speed with proper consideration for safety.
- 2) The officer will call out and control all evolutions.
- 3) Recommended time: 3 minutes.

**Critical Criteria:**

- 1) Correct pump pressure, 150 gpm minimum for all 1 3/4" lines or preset CAFS equal to 100 gpm minimum.
- 2) PPE worn correctly, facepiece in place, no visible skin, and cylinder fully on.
- 3) Crew will have all appropriate hand tools, lights, blowers, TIC, etc. as necessary for entry.
- 4) Proper size up accomplished prior to entry.

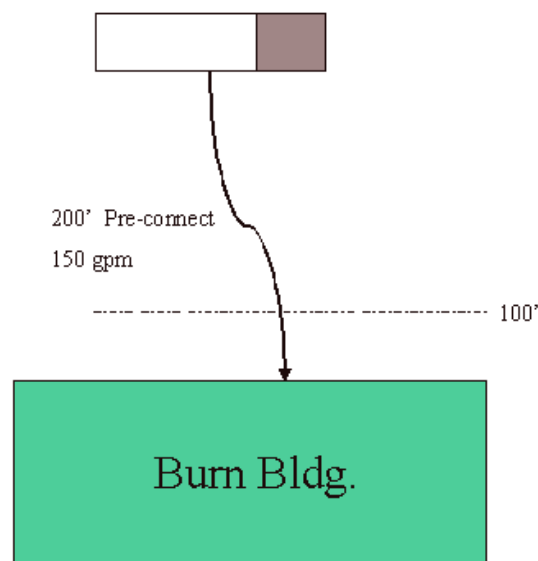

**Instructions:** This evolution simulates a basic residential fire attack with hydrant supply utilizing 2 or more companies and a minimum of 5 members wearing full PPE. Time starts when the first person steps off the apparatus. The second company arrives 30 seconds after the first. Time will stop when the air is bled from the hose, nozzle pattern is set and firefighters are breathing air and prepared for entry. Two members must be on each line at completion.

**Given:** Pumping apparatus and second company of any type

**Conditions:**

- 1) Evolutions should be executed at normal working speed with proper consideration for safety.
- 2) The officer will call out and control all evolutions.
- 3) Recommended time: 3 minutes.

**Critical Criteria:**

- 1) Correct pump pressure, 150gpm minimum for all 1 3/4" lines or preset CAFS equal to 100 gpm minimum.
- 2) 1st line can be charged off tank water, 2nd line must have established a water source.
- 3) PPE worn correctly, facepiece in place, no visible skin, and cylinder fully on.
- 4) Crew will have all appropriate hand tools, lights, blowers, TIC, etc. as necessary for entry.
- 5) Proper size up accomplished prior to entry.

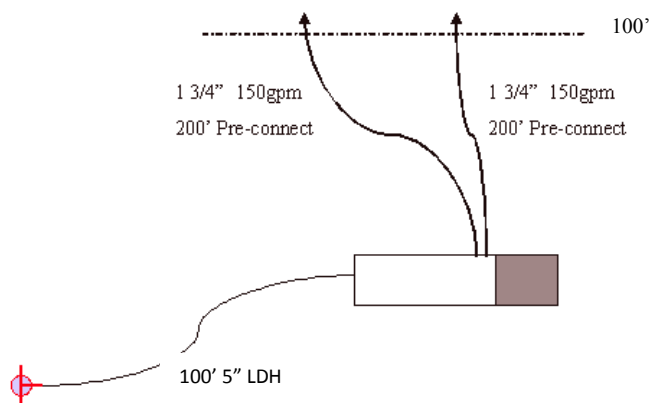

## I. Size-up

- A. Initial size up and radio report
- B. 360° size up
- C. Entry decision. Do we go interior? Buddy (READY) checks complete.

## II. Engine placement

- A. Generally to "A" side, pulling past for view of 3 sides.
- B. Leave room for Ladder
- C. Outside of collapse zone
- D. Outside of radiant heat zone for worst case fire
- E. Placed for effective hose line deployment.
- F. Placed for safety of Engineer from uncontrolled traffic.

## III. Line selection

- A. 1 ¾"
  1. Residential structures
  2. Room and contents fire
  3. Outside fires (i.e. dumpsters, sheds)
- B. 2 ½"
  1. Commercial occupancies
  2. Advanced fires (i.e. well involved)
  3. Defensive fire
  4. Unable to determine size or extent of fire
  5. Large or un-compartmented areas
  6. Tons of water situations.
  7. Standpipe operations

## IV. Line length determination

1. Will a pre-connect reach?
2. If not, calculate distance to door, add 1 stick per floor, and interior distance to fire.

## V. Hydrant supply

1. Attach gate valve to unused 2 ½" port.
2. May use storz steamer connection. Do not connect to threaded steamer connection.
3. Beware of hose hanging up in the bed, uncontrolled traffic, and other hazards

## VI. Is this a CAFS fire?

1. CAFS capable engine?
2. If so, we default to a CAFS attack unless conditions discourage it.
  - a. Not for sprinkler or standpipe use due to corrosive effect and possible contamination of domestic water sources.
  - b. Large, defensive fires may require water supply into pump instead of the direct tank fill for adequate volume.
3. Are command, the nozzle operator, and the Engineer on the same page?
  - a. Class A foam or Class B?
  - b. Fog nozzle removed (use smooth bore)

## VII. Is this a PPA fire?

1. PPA is an coordinated initial attack tactic as opposed to PPV being a coordinated ventilation tactic that can be called for at anytime during the incident.
2. Building will allow enough accessible exit points.
3. Officer can do a 360° and open up exit points.
4. Properly placed fan pressurizes entry door without blowback.
5. Firefighters are not already interior.

## VIII. Correct pump pressures.

**Instructions:** This evolution simulates a basic fire attack with water supply utilizing 2 or more companies and a minimum of 5 members wearing full PPE. Time starts when first person steps off apparatus. Second company arrives 30 seconds after first. Time ends when all steps below are complete and the members on the attack lines have their face piece in place. Two members must be on each line at completion.

**Given:** Pumping apparatus and second company of any type

**Conditions:**

- 1) Evolutions should be executed at normal working speed with proper consideration for safety.
- 2) The officer will call out and control all evolutions.
- 3) Recommended time: 4 minutes.

**Critical Criteria:**

- 1) Correct pressure according to DFRA pump chart, 150gpm minimum for all 1 ¾" lines or preset CAFS equal to 100 gpm minimum..
- 2) 1st line can be charged off tank water, 2nd line must have established a water source.
- 3) PPE worn correctly, facepiece in place, no visible skin, and cylinder fully on.
- 4) Proper size up accomplished prior to entry.

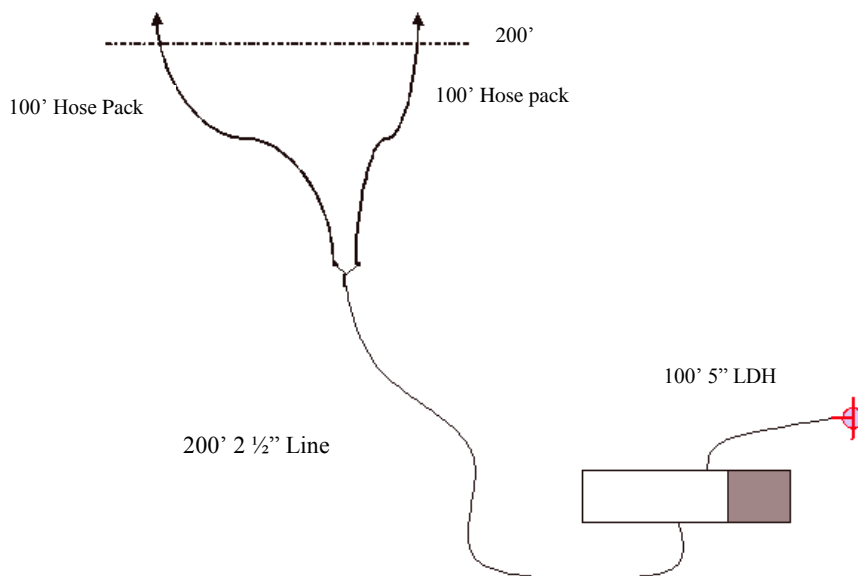

**Purpose:**

To quickly extend two manageable attack lines for fire operations with minimal friction loss and maximum GPM.

**I. Size-up**

- A. Initial size up and radio report
- B. 360° size up
- C. Entry decision. Do we go interior? Buddy (READY) checks complete.

**II. Engine placement**

- A. Generally to "A" side, pulling past for view of 3 sides.
- B. Leave room for Ladder
- C. Outside of collapse zone
- D. Outside of radiant heat zone for worst case fire
- E. Placed for effective hose line deployment.
- F. Placed for safety of Engineer from uncontrolled traffic.
- G. If a long rural driveway send someone to scout first if possible.

**III. Line selection****A. 1 ¾"**

1. Residential structures
2. Room and contents fire
3. Outside fires (i.e. dumpsters, sheds)

**B. 2 ½"**

1. Commercial occupancies
2. Advanced fires (i.e. well involved)
3. Defensive fire
4. Unable to determine size or extent of fire
5. Large or un-compartmented areas
6. Tons of water situations.
7. Standpipe operations
8. Long attack hose lay. Less friction loss with 2.5"

**C. 2 ½" to two 1 ¾"**

1. Commercial occupancies.
2. Multiple exposure protection distant to apparatus.
3. Flanking actions.
4. External standpipe.
  - a. 2 ½" Pre-connect. If it is to be deployed on level ground solely for reach or volume, consider pre-connect.
  - b. Flat load. If it is to be taken some distance around obstacles or to different floors, consider flat load as it is easier to shoulder load.

**IV. Line length determination**

1. Will a pre-connect reach?
2. If not, calculate distance to door, add 1 stick per floor, and interior distance to fire.

## V. Hydrant supply

1. Attach gate valve to unused 2 ½" port.
2. May use storz steamer connection. Do not connect to threaded steamer connection.
3. Beware of hose hanging up in the bed, uncontrolled traffic, and other hazards

## VI. Is this a CAFS fire?

1. CAFS capable engine?
2. If so, we default to a CAFS attack unless conditions discourage it.
  - a. Not for sprinkler or standpipe use due to corrosive effect and possible contamination of domestic water sources.
  - b. Large, defensive fires may require water supply into pump instead of the direct tank fill for adequate volume. .
3. Are command, the nozzle operator, and the Engineer on the same page?
  - a. Class A foam or Class B?
  - b. Fog nozzle removed (use smooth bore)
  - c. If using the flat load the Engineer will have to connect to a CAFS discharge

## VII. Is this a PPA fire?

1. PPA is an coordinated initial attack tactic as opposed to PPV being a coordinated ventilation tactic that can be called for at anytime during the incident.
2. Building will allow enough accessible exit points.
3. Officer can do a 360° and open up exit points. Take a tool.
4. Properly placed fan pressurizes entry door without blowback.
5. Firefighters are not already interior.

## VIII. Correct pump pressures.

## VIII. Roles and Responsibilities.

1. Tactics decided by officer, tasks by crew.
2. Division of tasks will depend on who is there and who will be there.
3. Each team should have a leader with a radio and a call sign designation

## CPT 2.4

## Deploying a Portable Monitor With Hydrant Supply

**Instructions:** This evolution simulates a basic defensive fire attack with water supply utilizing 1 company and a minimum of 3 members wearing full PPE. Time starts when first person steps off apparatus. Time ends when all steps below are complete and the members on the line have monitor in operation.

**Given:** A pumping apparatus with Quick Attack Monitor or deployable deck gun.

**Conditions:**

- 1) Evolutions should be executed at normal working speed with proper consideration for safety.
- 2) The officer will call out and control all evolutions.
- 3) Recommended time: 4 minutes.

**Critical Criteria:**

- 1) Correct pressure according to DFRA pump chart and manufacturer's recommendation for the specific monitor flowing 500gpm min.
- 2) Line can be charged off tank water, but stream must be uninterrupted while a water source is established.
- 3) PPE must be worn correctly.
- 4) Monitor must not be operated below 35° safety stop. Operator will insure safety stop is engaged.

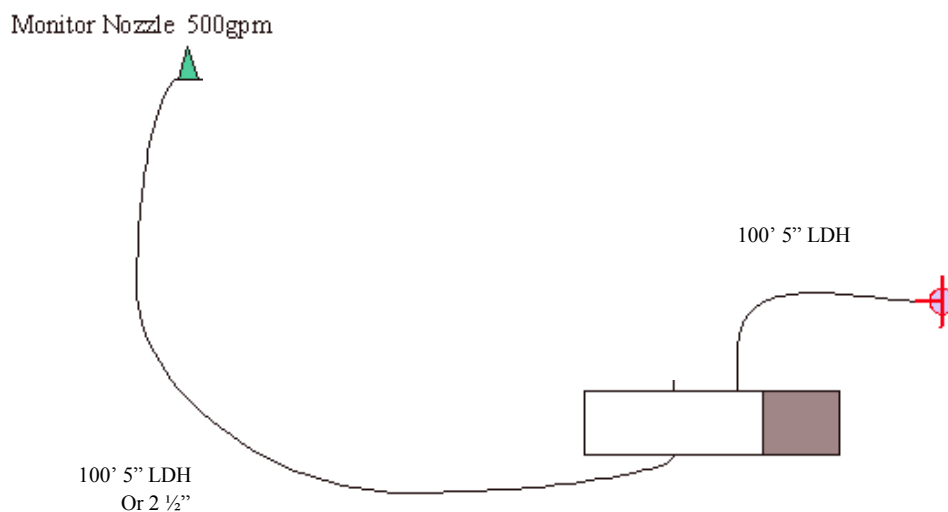

## Purpose:

To quickly deploy a portable monitor for defensive fire operations which may involve quick fire attack or exposure protection

### I. Size-up

- A. Initial size up and radio report
- B. 360° size up
- C. "No go" entry decision.

### II. Engine placement

- A. Generally to "A" side, pulling past for view of 3 sides.
- B. Leave room for Ladder
  1. Potential rescue operations
  2. Exposure protection
    - a. Closest exposure
    - b. Nearest downwind exposure
    - c. Most savable exposure (Where can we stop this fire?)
- C. Outside of collapse zone
- D. Outside of radiant heat zone for worst case fire
- E. Placed for effective hose line deployment.
- F. Placed for safety of Engineer from uncontrolled traffic.
- G. If a long rural driveway, send someone to scout first if possible.
- H. Lay a 5" line in. This will be water intensive. LDH should stay to the side of the driveway when possible.

### III. Line selection

- A. 2 ½"
  1. Quick Attack Monitor (500 gpm max)
  2. Play pipe with large smooth bore
- B. 5"
  1. Portable Deck guns
  2. Long lays to Quick Attack Monitors.

### V. Hydrant supply

1. Attach gate valve to unused 2 ½" port.
2. May use storz steamer connection. Do not connect to threaded steamer connection.
3. Beware of hose hanging up in the bed, uncontrolled traffic, and other hazards

### VI. Is this a CAFS fire?

1. CAFS capable engine?
2. If so, we default to a CAFS attack unless conditions discourage it.
  - a. Not for sprinkler or standpipe use due to corrosive effect and possible contamination of domestic water sources.
  - b. Large, defensive fires may require water supply into pump instead of the direct tank fill for adequate volume. .

### 3. Are command, the nozzle operator, and the Engineer on the same page?

- a. Class A foam or Class B?
- b. Fog nozzle removed (use smooth bore)
- c. If using the flat load the Engineer will have to connect to a CAFS discharge

### VIII. Correct pump pressures.

**Instructions:** This evolution simulates a basic commercial or residential fire attack with hydrant supply utilizing 2 or more companies and a minimum of 5 members wearing full PPE. Time starts when the first person steps off the apparatus. The second company arrives 30 seconds after the first. Time will stop when the air is bled from the hose, nozzle pattern is set and firefighters are breathing air and prepared for entry. Two members must be on each line at completion.

**Given:** Pumping apparatus and second company of any type

**Conditions:**

- 1) Evolutions should be executed at normal working speed with proper consideration for safety.
- 2) The officer will call out and control all evolutions.
- 3) Recommended time: 4 minutes.

**Critical Criteria:**

- 1) Correct pump pressure, 250gpm minimum for all 2 1/2" lines or preset CAFS minimum of 185 gpm .
- 2) 1st line can be charged off tank water, but must have established a water source to flow.
- 3) PPE worn correctly for situation.

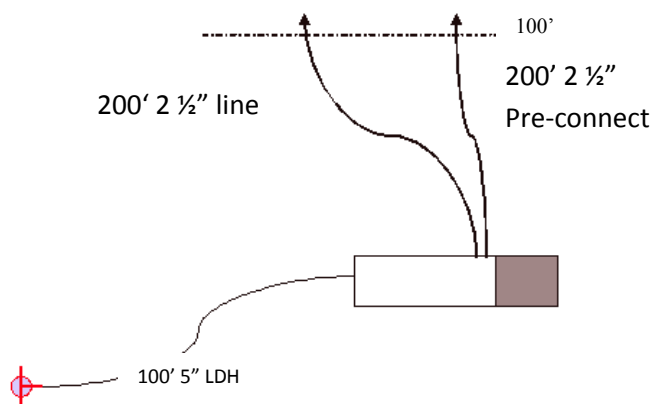

**Instructions:**

This evolution is intended to practice Single Firefighter Ladder techniques using straight ladders and small extension ladders ranging in size from 14-24 feet. Demonstrate the appropriate task using a leg lock and proper ladder handling techniques.

**Given:**

Apparatus, Ladder(s) of various lengths up to 24', Tools; Building/Structure prop, and PPE.

**Conditions:**

1. The evolution will be carried out at normal speed with proper consideration given to safety.
2. The task to be performed will be decided by the officer.

**Critical Criteria:**

1. Don appropriate PPE.
2. Communicate action plan to crew members.
3. Select the appropriate ladder for the task assigned.
  - a. Window ventilation (up-wind side).
  - b. Victim rescue from window (top rung at window sill).
  - c. Hose operation at window (top rung at top of window).
  - d. Roof operations (3-5 rungs above roof).
4. Remove ladder from apparatus.
5. Use single Firefighter carry to move ladder to assigned location.
6. Place butt of ladder against structure.
7. "Rung Raise" the ladder against structure.
  - a. Straight Ladders
    - i. Adjust butt of ladder for correct climbing angle.
    - ii. Position ladder against structure for task assigned.
  - b. Extension Ladder
    - i. Extend fly section to desired length for appropriate task.
    - ii. Tie off halyard.
    - iii. Rotate ladder so fly section is out.
    - iv. Position ladder against structure for task assigned.
8. Firefighter ascends ladder, uses leg lock, performs assigned task.

**Watch out situations:**

1. Proper PPE worn and utilized.
2. Look for overhead obstructions and hazards.
3. Check ground surface for stability and level.

**Instructions:**

This evolution is intended to practice Two Firefighter Ladder techniques using extension ladders ranging in size from 24-28 feet. Demonstrate the appropriate task using a leg lock and proper ladder handling techniques.

**Given:**

Apparatus, Extension Ladder(s) of various lengths from 24'-28', Tools; Building/Structure prop, and PPE.

**Conditions:**

1. The evolution will be carried out at normal speed with proper consideration given to safety.
2. The task to be performed will be decided by the officer.

**Critical Criteria:**

1. Don appropriate PPE.
2. Communicate action plan to crew members.
3. Select the appropriate ladder for the task assigned.
  - a. Window ventilation (up-wind side).
  - b. Victim rescue from window (top rung at window sill).
  - c. Hose operation at window (top rung at top of window).
  - d. Roof operations (3-5 rungs above roof).
4. Remove ladder from apparatus.
5. Use Two Firefighter carry to move ladder to assigned location.
6. Place butt of ladder at deployment area of structure.
7. Utilize a "Rung Raise" or "Beam Raise" to place the ladder against structure.
  - a. Rung raise when perpendicular to the structure.
  - b. Beam raise when parallel to the structure.
8. Place Extension Ladder against structure.
  - i. Extend fly section to desired length for appropriate task.
  - ii. Tie off halyard.
  - iii. Rotate ladder so fly section is out.
  - iv. Position ladder against structure for task assigned.
9. Firefighter ascends ladder, uses leg lock, performs assigned task.

**Watch out situations:**

1. Proper PPE worn and utilized.
2. Look for overhead obstructions and hazards.
3. Check ground surface for stability and level.

**Instructions:**

This evolution is intended to practice Three Firefighter Ladder techniques using extension ladders of 35 feet. Demonstrate the appropriate task using a leg lock and proper ladder handling techniques.

**Given:**

Apparatus, Extension Ladder (35'), Tools, Building/Structure prop, and PPE.

**Conditions:**

1. The evolution will be carried out at normal speed with proper consideration given to safety.
2. The task to be performed will be decided by the officer.

**Critical Criteria:**

1. Don appropriate PPE.
2. Communicate action plan to crew members.
3. Select the appropriate ladder for the task assigned.
  - a. Window ventilation (up-wind side).
  - b. Victim rescue from window (top rung at window sill).
  - c. Hose operation at window (top rung at top of window).
  - d. Roof operations (3-5 rungs above roof).
4. Remove ladder from apparatus.
5. Use Three Firefighter carry to move ladder to assigned location.
6. Place butt of ladder at deployment area of structure.
7. Utilize a "Rung Raise" to place the ladder against structure.
8. Place Extension Ladder against structure.
  - i. Extend fly section to desired length for appropriate task.
  - ii. Tie off halyard.
  - iii. Rotate ladder so fly section is out.
  - iv. Position ladder against structure for task assigned.
9. Firefighter ascends ladder, uses leg lock, performs assigned task.

**Watch out situations:**

1. Proper PPE worn and utilized.
2. Look for overhead obstructions and hazards.
3. Check ground surface for stability and level.

**Instructions:**

This evolution is intended to practice Vertical Ventilation techniques using various methods to access the roof to perform ventilation. Methods for access are ground ladders and Aerial Apparatus. Demonstrate the proper roof sounding techniques, equipment usage, and cutting methods to obtain the performance outcome.

**Given:**

Aerial Apparatus, Extension Ladder(s) 24'-35', Roof Ladder, Tools, Building/Structure prop, and PPE.

**Conditions:**

1. The evolution will be carried out at normal speed with proper consideration given to safety.
2. The task to be performed will be decided by the officer.

**Critical Criteria:**

1. Don appropriate PPE.
2. Communicate action plan to crew members.
3. Select the appropriate tools and equipment.
4. Select appropriate ladders for roof ventilation.
5. Locate position for opening at highest point on roof above fire.
6. Properly place and secure ground ladder for roof ventilation.
7. Correctly carry roof ladder while ascending ground ladder and place in position on roof. (make sure that placement is upwind from intended opening)
8. Move tools to roof. (start and stop all power tools on ground)
9. Sound roof for integrity and to locate roof rafters or joists.
10. Make an opening at least 4' x 4'.
11. Remove appropriate roof materials after cuts are completed.
12. Using a pike pole, push in ceiling materials.
13. Exit roof immediately upon completion of task.

**Watch out situations:**

1. Proper PPE worn and utilized.
2. Look for overhead obstructions and hazards.
3. Appropriately sound roof.
4. Check ground surface for stability and level.
5. Keep tools secure at all times.

**Instructions:** This evolution simulates a low angle embankment rescue utilizing 2 or more companies and a minimum of 6 members plus 3 attendants (see 4.2). Time starts when the first person steps off the apparatus. The second company arrives 30 seconds after the first. Time will stop when the safety check is completed and the system is ready to accept a load.

**Given:** A Rescue and second company of any type.

**Conditions:**

- 1) Evolutions should be executed at normal working speed with proper consideration for safety.
- 2) The officer will call out and control all evolutions.
- 3) Recommended time: **15 minutes:** Includes setting a fixed line down to site and setting up a main line lowering system with separate rescue belay rigged to litter. Attendants also rigged to litter with proper PPE.
- 4) A change-over from a lower to a raise (Simple 3:1 MA using the main line with a self-minding ratchet) will also be demonstrated. Recommended time: **5 minutes**

**Critical Criteria:**

✿ **Scene Size–Up:**

- Establish need for technical rescue (based on Dispatch info - occurs on the way to call)
- Establish a structured Command
- Objective hazards? (traffic control, HAZMAT, unstable vehicle, fire suppression, etc)
- Extrication required?
- Number of patients?
- Mechanism of accident (high speed, rollover, heavy damage, ejection, distance down embankment, and etc)

✿ **Develop Rescue Plan** (look for safest simplest solution)

- Locate a safe fall line (the edge location where the rescue ropes will align (perpendicular to edge) and run to the accident site. This will include patient access considerations.
- Based on the edge location, protect location and position key apparatus (Rescue Truck) as they arrive
- Determine Main and Belay Focal Point locations with anchors

✿ **Brief Team On Rescue Plan**

- Outline objective hazards
- Establish an efficient central area for team equipment
- Establish a simplex channel for operations
- Maintain a structured command and communication format
- Enforce PPE (helmet and gloves) and proper edge line requirements, as indicated past safe zone, at accident site.

CPT 4.1 Low Angle Lowering and Raising System with Belay, Con't

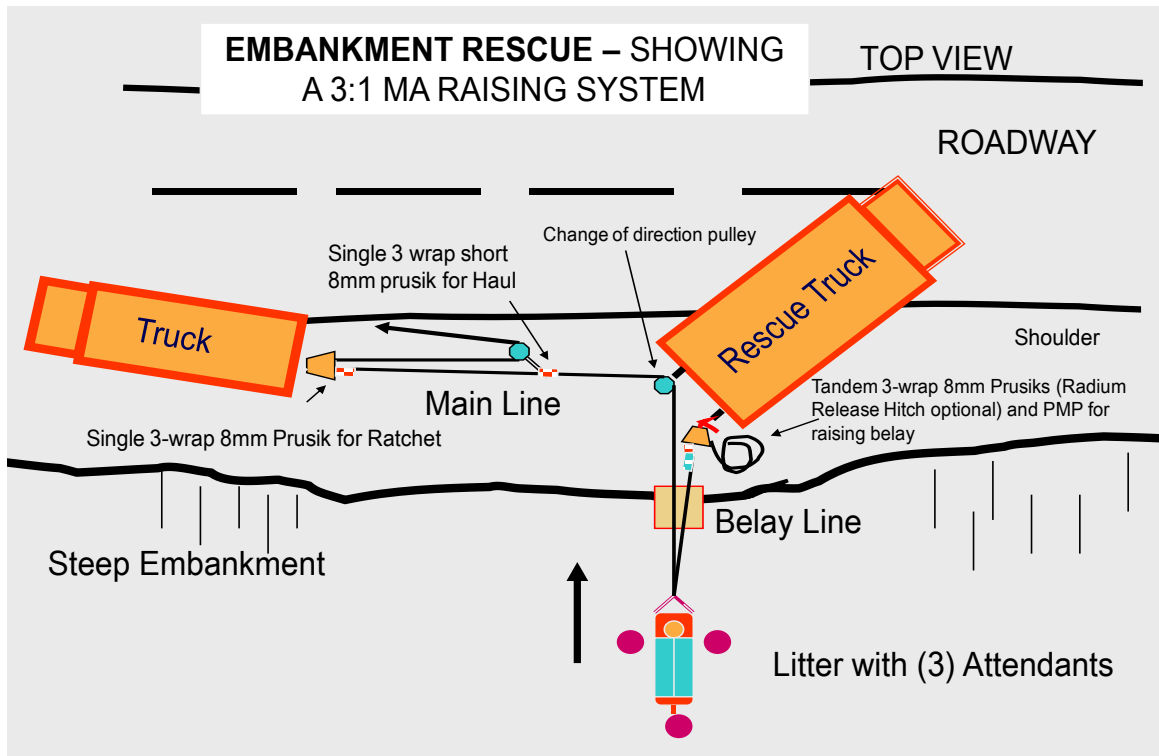
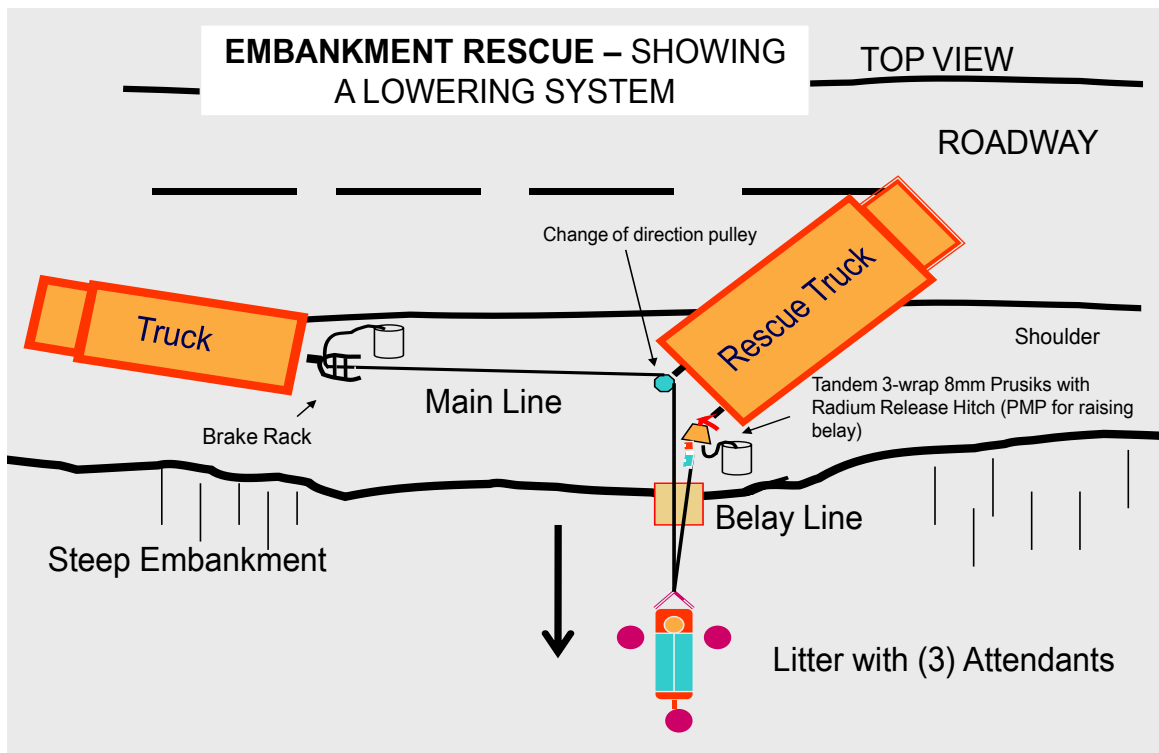

## MAIN LINE COMPONENTS



**Lowering System**



**Raising System with a simple 3:1 MA Pulley System with a self-minding ratchet**

## RESCUE BELAY COMPONENTS



**Rescue Belay for a Lowering**



**Belay for a Raising (PMP added)**

**Instructions:** This evolution incorporates patient securing in the litter for a low angle embankment rescue utilizing a minimum of 3 attendants. Time starts when the patient (strapped to a Long Spine Board -LSB) is transferred to the litter. Time will stop when the safety check is completed and the secured patient is ready to be moved in a head up orientation in the litter connected to the main and belay line system.

**Given:** Rescue with minimum 3 rescuers

**Conditions:**

- 1) Evolutions should be executed at normal working speed with proper consideration for safety.
- 2) The officer will call out and control all evolutions.
- 3) Recommended time: **7 minutes**.

**Critical Criteria:**

Injuries noted and accounted for in system.

Padding, comfort, accessibility, and weather protection are all considered.

The patient is properly secured in the litter and connected to the main line and belay system.

Patient movement in the litter is minimized.

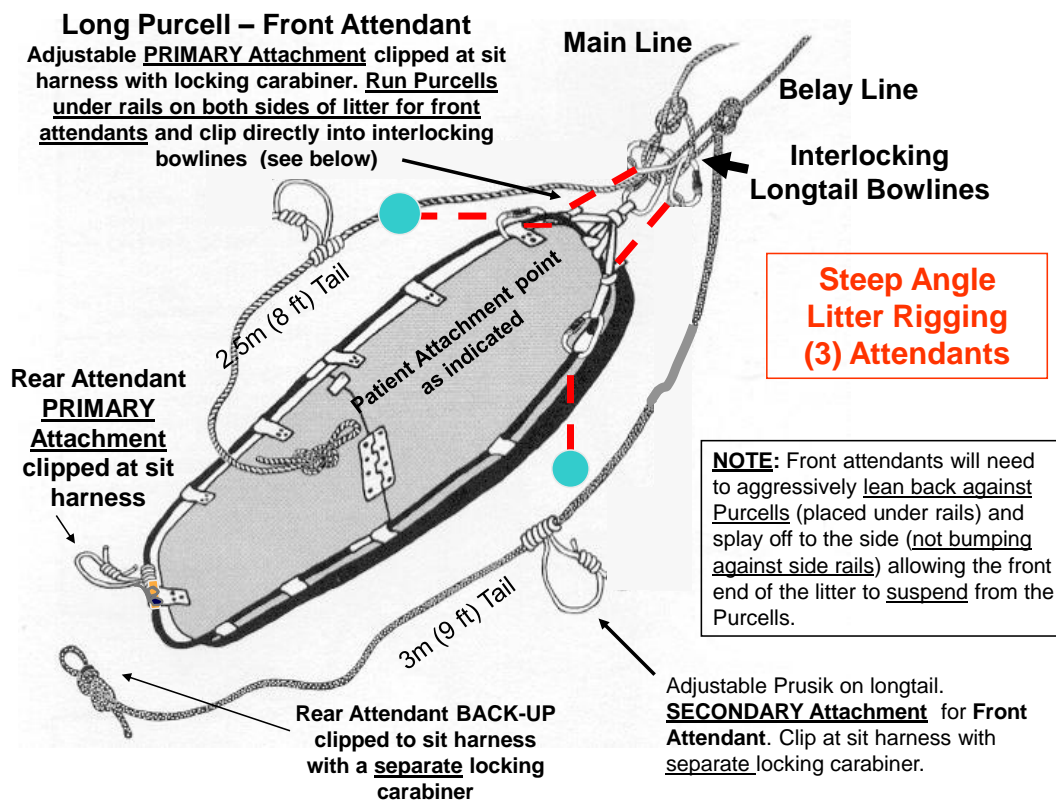

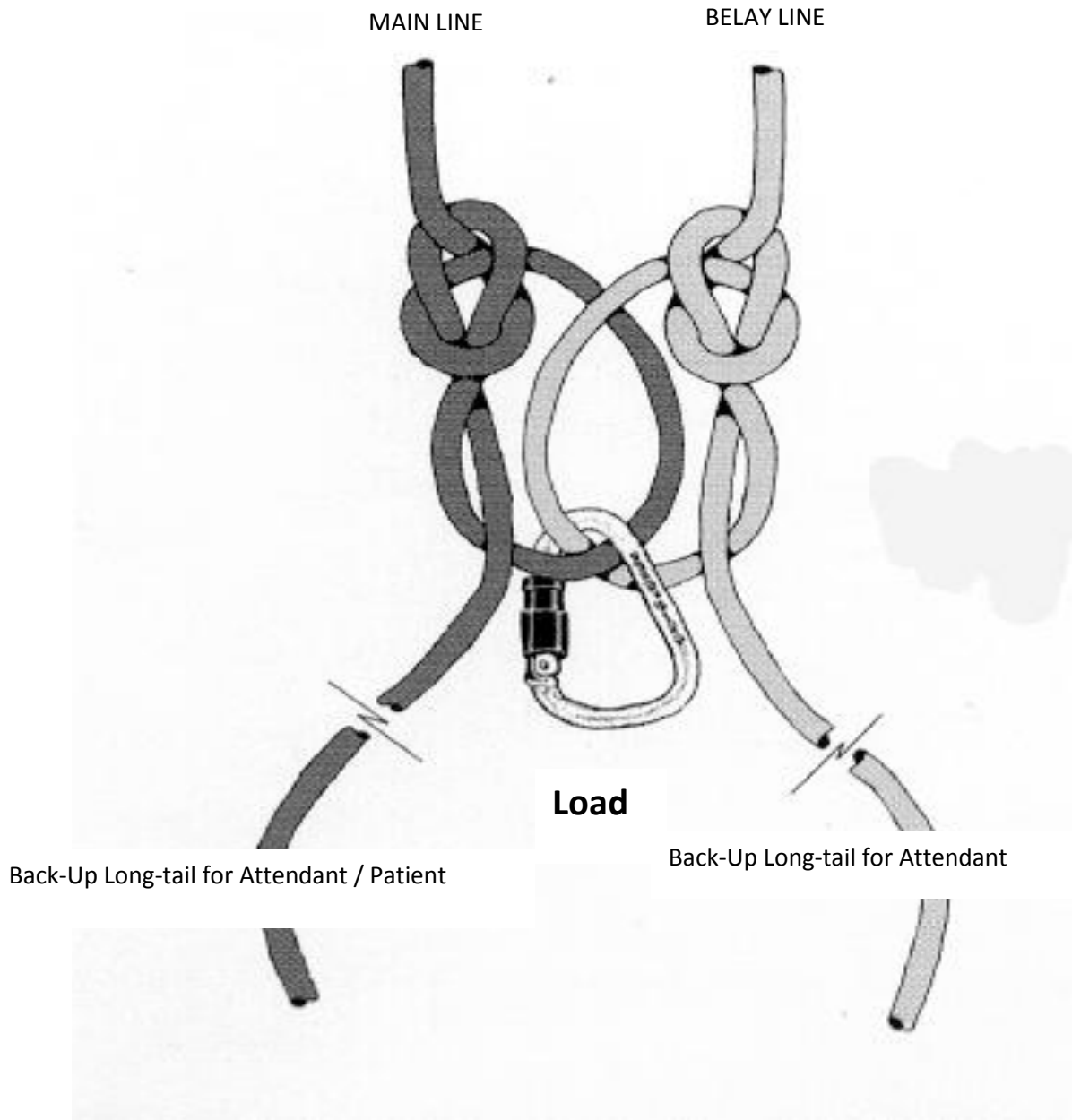

**Long-Tail Interlocking Bowlines to Attach to the Load**

**Instructions:**

Stabilization is the act of reducing, removing, and mitigating the hazards at the scene. This evolution is intended to practice Stabilization of a vehicle in various positions for the purpose of extrication. Using various methods, tools, and struts, you will be able to stabilize and secure a vehicle for the purpose of extrication.

**Given:**

Cribbing, wedges, struts, airbags, PPE, protective eyewear, hose line.

**Conditions:**

1. The evolution will be carried out at normal speed with proper consideration given to safety.
2. The task to be performed will be decided by the officer.

**Critical Criteria:**

1. Don appropriate PPE including eye protection.
2. Communicate action plan to crew members.
3. Mitigate traffic hazards.
4. Mitigate fire hazards and exposures.
5. Assign one person (per vehicle) to perform a 360 to identify all hazards.
  - a. Downed power lines
  - b. Animals
  - c. Terrain issues
  - d. Ice and snow
  - e. Vehicle hazards
6. Mitigate electrical hazards on vehicle
7. Create a staging area for all equipment outside the work/rescue zone.
8. Select the appropriate tools and equipment.
- 9a. Stabilize vehicle on wheels.
  - A. Chock both sides of one or more wheels
  - B. Crib under the rocker panel in at least 3 places, preferably 4
  - C. Do not pound in wedges, use only enough pressure to create a snug fit
- 9b. Stabilize vehicle laying on side.
  - A. Stabilize the body of the car (wedges on fenders or at A and C posts)
  - B. Stabilize the underside of car with Rescue Jacks, 4x4, etc.
- 9c. Stabilize vehicle on roof.
  - A. Chock/crib the space between back of vehicle and ground
  - B. Chock/crib the space in front of the windshield for added stability

**Watch out situations:**

Proper PPE must be worn and/or utilized.

Approved eye protection worn at all times when inside the control zone.

Protect patient from debris and noise.

Remember the 5-10-20 rule for airbags:

Maintain a minimum of 5 inches from side impact airbags.

Maintain a minimum of 10 inches from steering wheel airbags.

Maintain a minimum of 20 inches from passenger side frontal airbags.

Hands/fingers on side of cribbing, not on top and bottom

Think ahead: Avoid placing cribbing or supports in an area that might have to be cut

Keep tools secure at all times.

## CPT 4.4 Vehicle Extrication-Portable and Fixed Hydraulic Power Units

**Instructions:** With a vehicle properly stabilized and other scene safety considerations addressed, set up and utilize various cutters, spreaders, and rams using a portable or fixed (apparatus mounted) hydraulic power unit.

**Given:** Apparatus equipped with an on board or portable hydraulic power unit and a stabilized vehicle for extrication.

### **Conditions:**

1. The evolution will be carried out at normal speed with proper consideration given to safety.
2. The task to be performed will be decided by the officer.
3. An extrication group supervisor may be assigned.

### **Critical Criteria:**

1. Don appropriate PPE including eye protection.
2. Communicate action plan to crew members.
3. All appropriate critical criteria from CPT 4.3, Vehicle Stabilization must be met.
4. Portable units:
  - Set up unit on firm, level ground uphill and upwind whenever possible.
  - Best practice is to attach tools and hoses prior to starting unit. This helps prevent accidental charging of lines that are not connected to tools.
  - Start engine and charge hydraulic lines.
5. Fixed units:
  - Engage generator
  - Best practice is to attach tools and hoses prior to turning unit on. This helps prevent accidental charging of lines that are not connected to tools.
  - Turn on unit and charge hydraulic lines.
6. Troubleshooting portable units.
  - Make sure all switches are in the correct position for that unit.
  - Make sure hydraulic lines are not charged.
  - Engines are equipped with low oil safety shut offs. If oil is present at plug and unit does not start, rotate the unit 90°. Continue this process until the oil level finds the sensor.
7. Troubleshooting fixed units.
  - Make sure all generator switches are engaged and generator is operating.
  - Check breaker panel if possible
  - If lines are charged and tool connection is not possible, yet the valve is not engaged, crack the valve slightly to attempt to bleed pressure from the system.

### **Watch out situations:**

1. Proper PPE must be worn and/or utilized.
2. Approved eye protection worn at all times when inside the control zone.
3. Protect patient from debris and noise.
4. Remember the 5-10-20 rule for airbags:
  - Maintain a minimum of 5 inches from side impact airbags.
  - Maintain a minimum of 10 inches from steering wheel airbags.
  - Maintain a minimum of 20 inches from passenger side frontal airbags.
5. Vehicle parts and pieces should be removed in a controlled manner and moved to a safe area.

**Instructions:**

This evolution is intended to practice Fill Site Operations for Tanker Shuttle. This evolution will encompass multiple fill sites such as hydrants, dry hydrants, and static water sources.

**Given:**

Type I engine, tanker(s), porta-tank, low level strainer, 50' of 1 3/4" hose, proper sections of drafting hose, (1 each of the previous items for every porta-tank), gated wye, spotter, water supply officer.

**Conditions:**

1. The evolution should be carried out at normal speed with proper consideration for safety.
2. The GPM required at the incident will dictate the water source.

**Critical Criteria:**

1. Place the engine on the most stable surface condition near water source. (Remember: the area is going to get wet)
2. Establish water supply communications with water supply officer and IC. (consider Ch4 Tac1) and assign a fill site manager as quickly as possible.
3. Select a water source based one of the 3 criteria.
  - a. Establish water supply utilizing Hydrant.
  - b. Establish water supply utilizing Dry Hydrant.
  - c. Establish static source water supply utilizing proper suction hose (length & elevation) and strainer.
4. Tanker arrives and makes connection between the tanker and engine using 4" line.
5. Fill tanker at a maximum of 100psi using engine.
  - d. Prioritize one tanker at a time to utilize your pump capacity.
  - e. A second supply can be connected to fill a second tanker when ready.
6. Disconnect supply line from TANKER.
7. Tanker proceeds back to scene.

**Orders and Watch out situations:**

1. Proper PPE is worn and utilized.
2. Spotters utilized anytime a tanker is backing.
3. Tanker driver is to remain in the driver's seat at all times.

**Instructions:**

This evolution is intended to practice Dump Site Operations for Tanker Shuttle. This evolution will encompass single and/or multiple 'porta-tanks' at a single dump site.

**Given:**

Type I engine, tanker(s), porta-tank, low level strainer, 50' of 1 3/4" hose, proper sections of drafting hose, (1 each of the previous items for every porta-tank), gated wye, spotter, water supply officer.

**Conditions:**

1. The evolution should be carried out at normal speed with proper consideration for safety.
2. The GPM required at the incident will dictate the number of porta-tanks.  
*"Rule of thumb: 250gpm per tank based on total fire flow"*
3. A suitable area to handle a pumper, and 1-3 porta-tanks that allows for adequate ingress and egress of moving tankers.

**Critical Criteria:**

1. Select a location for dump site operations within 1000' of fire ground when possible. Place the engine on the most stable surface condition allowing for tank placement. (Remember: the area is going to get wet)
2. Attach supply engine to attack engine with 5" hose.
  - a. Establish flow to attack engine.
  - b. Do not drop supply engine water tank below 1/4 tank.
3. Establish water supply communications with water supply officer and IC. (Consider Ch4 Tac1) and assign a dump site manager as quickly as possible.
4. Determine the number of tanks needed for fire ground operations.
5. Tanker arrives at dump site
  - a. Drop porta-tank off truck.
  - b. Leave one (1) section of hard suction at site. (This section of hose needs to have threaded end)
  - c. Leave low-level strainer and one (1) stick of 1 3/4" hose.
6. Deploy Porta-tank
  - a. Set up tank with drain downhill.
  - b. Set primary tank within 15' of supply engine.
  - c. Set up additional tanks in such a manner that allows for ease of fill from tankers.
7. Fill porta-tank with tanker water.
  - a. Tankers do not move without a spotter.
  - b. Drivers are to remain in the driver's seat.
  - c. When instructed, open discharge chute.
  - d. When instructed, close chute and proceed to fill site.

8. Once supply tank is established, a changeover from truck water to porta-tank water needs to be performed. (Ensure that truck water is replenished)
9. If multiple tanks are used. Supply engine will need to perform the following:
  - a. Connect gated wye onto discharge.
  - b. Connect the threaded suction hose to the low level strainer and connect the 1 ¾" hose to the strainer. Place completed assemble into additional tank. (This now becomes your jet siphon)
    - i. Discharge end of suction hose needs to be routed to next tank and tied down to the frame. Do not allow the end of the hose to submerge into tank.
    - ii. Repeat as needed for additional tanks.
  - c. Connect the other end of the 1 ¾" hose to the gated wye.
10. Supply engine must maintain a full onboard tank and maintain water movement into supply tank utilizing the jet siphons at 100psi.
11. Keep water supply officer informed regularly of water status.

**Orders and Watch out situations:**

1. Proper PPE is worn and utilized.
2. Spotters utilized anytime a tanker is backed up.
3. Tanker driver is to remain in the driver's seat at all times.
4. Tie all suction hose to the rails of the frame.
5. Any issues with water supply need to be communicated to water supply officer.
6. Avoid pinch point areas on the porta-tank.
7. Be aware of where all the excess water is to be disposed of.
8. Avoid driving tankers with a partial tank of water. Drive them full or empty.

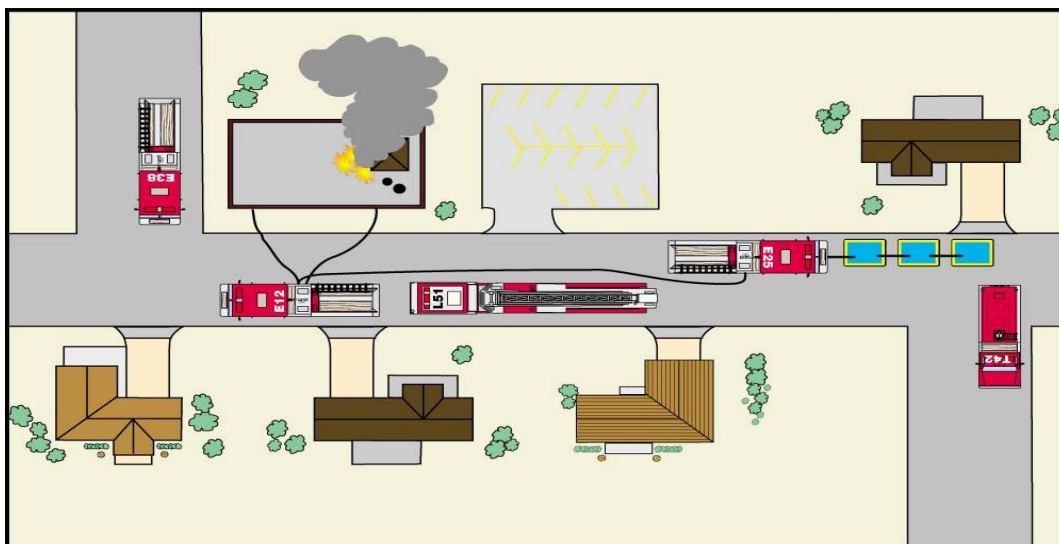

**Instructions:** This evolution is intended to practice in the use of the New Generation fire shelter which is carried as PPE and used only as a last resort. The fire shelter increases your chances of survival in the event of a burn over situation. The shelter is not a substitute for following the Fire orders.

**Given:** A new generation training fire shelter, a representative light fuel type, full PPE, hand tool and line pack. A fan will be used to simulate winds that may be encountered.

**Conditions:** The evolution should be carried out at full speed in full PPE running 30 ft. while dropping non essential gear. At 10 ft from an operating fan clear a 4'x8' area and shake out shelter. Enter shelter with back to the wind and feet toward fire bringing radio and water. Hold shelter floor down with feet, hands and elbows with arms under the straps. Keep shelter away from body. The deployment should take < 25 seconds.

**Critical criteria:**

1. The shelter will be carried during all phases of fire suppression and prescribed fire operations.
2. Treat shelter with respect and carry where it can easily be reached on the run.
3. Inspect shelter when issued, at the beginning of and every two weeks during fire season. Look for gray color of vinyl bag, tears along edge > ¼", dents or punctures over 1" wide or ½" of foil missing. Remove from service if any of above.
4. The shelter will reflect radiant heat it is not designed for direct flame contact.
5. Wear full PPE including gloves and hard hat.
6. Drop pack; bring only radio and drinking water into shelter.
7. Never wet clothing or bandana in shelter, moist heat will cause more damage to skin and airway.
8. Avoid hazardous terrain and heavy fuels.
9. Consider burn out if time allows.
10. Be prepared for staying up to 90 minutes and multiple flame fronts.
11. Keep your face on the ground for the coolest air.
12. Stay hydrated and in communication.
13. Never share a shelter unless someone is without.
14. Stay in shelter until temperatures have significantly cooled or a supervisors says it is safe.

**Instructions:** Cut fireline through wildland vegetation. Fireline width is to be 1 ½ times the height of available fuel to mineral soil. The width necessary will depend on fuel type and density.

**Given:** Fireline hand tools and an area of representative fuel type to construct fireline and mop up.

**Conditions:**

- 1) The evolution should be carried out at normal speed in an area of a representative wildland fuel type with proper consideration for safety.
- 2) A simulated fire area and the attack method to be used including the fireline standards.

**Critical criteria:**

Line construction:

- 1) Establish crew organization.
- 2) Consider fuel type, moisture, spotting and rolling debris.
- 3) Select appropriate tools and tool order for fuel model.
- 4) Continually verbalize LCES and identify any line hazards.
- 5) Break up vertical arrangement of fuels through limbing or removal of ladder fuels.
- 6) Construct scratch line to mineral soil from an *anchor point* to specified point using the *one lick or bump up method*.
- 7) Keep proper spacing during tool use.
- 8) Remove any roots that may threaten line. Cup trench for any threat of rolling material
- 9) Strengthen and patrol line after construction. Consider cold trailing and checking for spots.

Mop up techniques:

- 1) Use senses sight, smell, hearing and touch to find burning materials and extinguish.
- 2) Work inward from control line working from hottest to coolest areas of fire. Consider gridding large areas.

Dry mop:

- 1) Use soil and hand tools to break up and extinguish.
- 2) *Bone pile, chunk* and consume or spread heavy concentrations of material

Wet mop:

- 1) Separate fuels with hand tools and extinguish with water or water and soil, consider surfactant.
- 2) PPE use for safe water application

Instructions: This evolution simulates an attack on a fast moving wildland fire where a mobile attack is not possible utilizing an engine crew of 2 or 3 members in full PPE. The application will also work well for a systematic mop up using water.

Given: A (type 6 or 3 brush truck with a full compliment hose, wyes or hose line tee valves, reducers and nozzles. A portable pump capable of producing 300 psi and a water source may be substituted. A simulated fire area should be laid out with fire condition and water use objective (hot spotting, wet lining, direct attack, mop up).

Conditions:

- 1) The evolution should be carried out at normal speed in an area of at least an acre of a representative wildland fuel type with proper consideration for safety.
- 2) Hose lay specifications and placement will be relayed by engine boss to crew members.

Critical criteria:

- 1) Place apparatus in a direction to quickly escape.
- 2) Have a method of communication established, either radio or water use hand signals.
- 3) Wear full PPE including eye protection when working with nozzles.
- 4) Lay 1 ½" trunk line to *anchor point*.
- 5) Lay 1" laterals to control *flank* and advance trunk line keeping continuous water flow capability.
- 6) Use a hose clamp or 1 ½" nozzle to advance third trunk line keeping continuous water flow capability.
- 7) Demonstrate proper water use technique.
- 8) Have hand tool work with nozzle personnel.
- 9) Use foam to increase effectiveness of water.

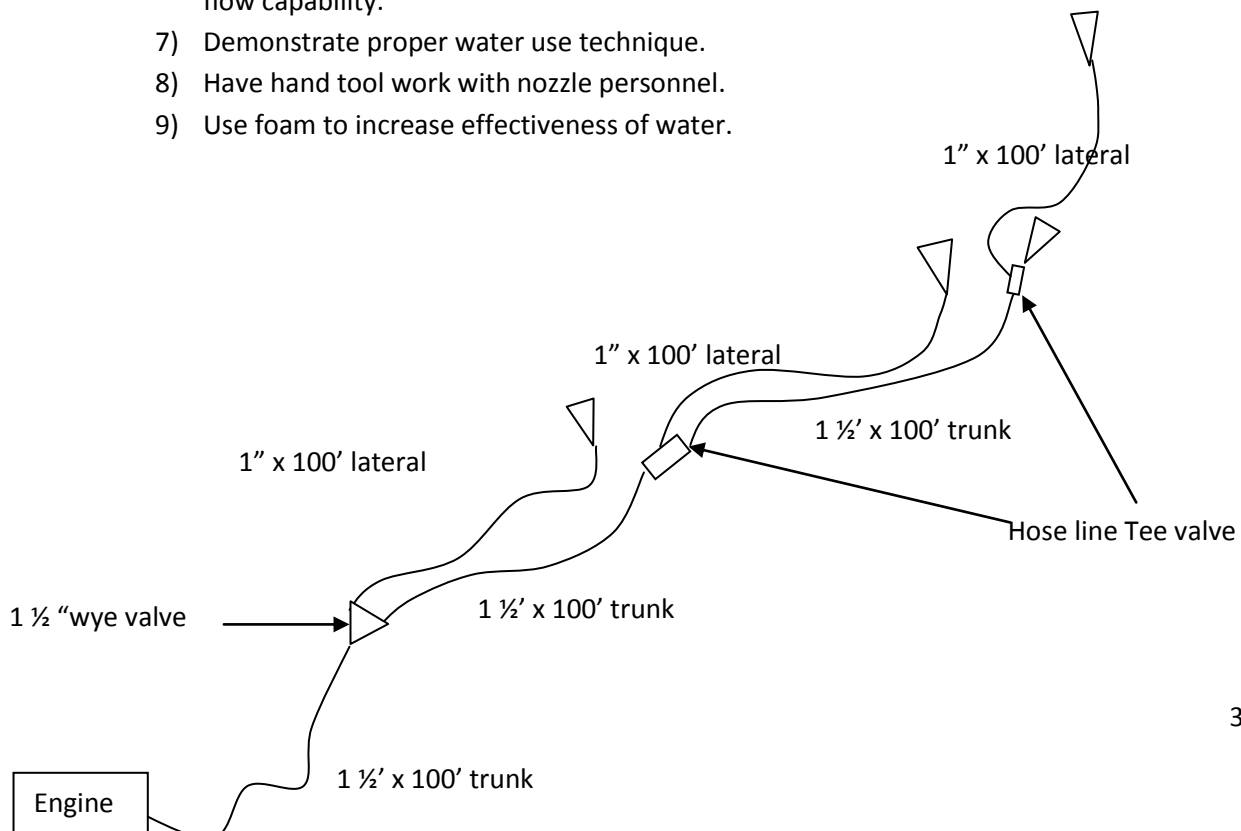

**I. Size up and Initial radio report**

1. Size
2. Status
3. Establish IC and name
4. Weather
5. Radio channel
6. Access routes
7. Special hazards or concerns
8. Additional resources needed

**II. The 10 Standard Fire Orders***Fire Behavior*

1. Keep informed on fire weather conditions and forecasts.
2. Know what your fire is doing at all times.
3. Base all actions on current and expected behavior of the fire.

*Fireline Safety*

4. Identify escape routes and safety zones and make them known.
5. Post lookouts when there is possible danger.
6. Be alert. Keep calm. Think clearly. Act decisively.

*Organizational Control*

7. Maintain prompt communications with your forces, your supervisor and adjoining forces.
8. Give clear instructions and insure they are understood.
9. Maintain control of your forces at all times.

*If 1-9 are considered, then...*

10. Fight fire aggressively, having provided for safety first.

The 10 Standard Fire Orders are firm. We don't break them; we don't bend them. All firefighters have the right to a safe assignment.

**III. The 18 Watch Out Situations**

1. Fire not scouted and sized up.
2. In country not seen in daylight.
3. Safety zones and escape routes not identified.
4. Unfamiliar with weather and local factors influencing fire behavior
5. Uninformed on strategy, tactics, and hazards.
6. Instructions and assignments not clear.
7. No communication link between crewmembers and supervisors.
8. Constructing line without safe anchor point.
9. Building line downhill with fire below.
10. Attempting frontal assault on fire.
11. Unburned fuel between you and the fire.
12. Cannot see main fire, not in contact with anyone who can.
13. On a hillside where rolling material can ignite fuel below.
14. Weather gets hotter and drier.
15. Wind increases and/or changes direction.
16. Getting frequent spot fires across line.
17. Terrain or fuels make escape to safety zones difficult.
18. Feel like taking a nap near fireline.

**IV. LCES**

**Look outs** –Experienced person(s) positioned to see the hazard and the firefighters with communication established.

**Communication**–Radio, hand signals, flagging, mirror, audible, and runners are available methods for communicating in different situations. Provide updates and situation changes, sound alarm early.

**Escape Routes**- Evaluate route and distance to Safety zone regularly considering fuel weather and terrain.

**Safety zones**- Survivable **without** fire shelter using clean burn, natural features or constructed. Upslope, downwind, or heavy fuels means larger Safety zone.

**V Fire Attack**

1. Common Denominators of Fire Behavior on Tragedy Fires
  - A. On relatively small fires or deceptively quiet areas of large fires
  - B. In relatively light fuels, such as grass and light brush.
  - C. With unexpected shifts in wind direction or speed.
  - D. When fire responds to topographic conditions and runs uphill.
2. Human Factor Barriers to Situational awareness
  - A. Low Experience level with local factors
  - B. Distraction from primary task
  - C. Fatigue
  - D. Stress reactions
  - E. Hazardous attitudes
3. Fireline construction standards considerations
  - A. Fuel type
  - B. Fuel moisture
  - C. Continuity and arrangement
  - D. Temperatures
  - E. Increase in wind
4. Methods of attack
  - A. Direct
  - B. Indirect
  - C. Flanking
5. Suppression techniques
  - A. Hot spotting
  - B. Cold trailing
  - C. Scratch line
  - D. Fire proofing fuel
  - E. Burning out

**VI. Mop up and securing**

Two types of mop up: dry and wet. Both involve separating and removing, or extinguishing burning materials, working from control line into interior.

1. Dry mop is performed using hand tools and soil. Techniques include *Bone piling*, *chunking and piling* and spreading heavy concentrations of fuels. Then scrape and use soil to cool. Turn logs and potential rolling material perpendicular to slope or *cup trench* below.

2. Wet mop is adding water, surfactants or foam to similar techniques used in dry mop up. Apply water in a fine spray with an off and on method. Work from unburned or hottest inward. Spray stir, spray and repeat. Straight stream is only used for penetration or reach and is the least efficient use of water. Use goggles when working near nozzles.

**VII. Special considerations**

1. Communicate to Durango Interagency Dispatch Center (DRC 385-1324) with size up information and location (Lat and Long). The SW Colorado Annual Fire Operating plan states fires have a 1 mile mutual aid zone for 4 hrs in the counties participating in the agreement.
2. Durango Interagency Dispatch Center (DRC) is assigned a primary and secondary Air to Ground VHF channels AIRGND 1 -172.275 and AIRGND 2- 172.325.
- 3.

References Fire line hand book, Incident response guide book, S-130 course materials, S-211 course materials.

# Company Performance Tasks (CPT's)

## Glossary of terms

**Assisted Ventilation:** This tactic uses mechanical or hydraulically generated pressure to influence and increase the exchange of fire effluent and air. Assisted ventilation includes the use of fog streams and fans to reduce pressure at the exhaust opening (negative pressure) and use of fans or blowers to increase pressure at the inlet opening (positive pressure).

**Attic Ladder:** Also called a Captains Ladder. A narrow collapsible ladder that can be used inside a building or structure to access attics and overhead areas.

**Authority Having Jurisdiction (or AHJ):** organization or agency with legal authority over a given type of incident (e.g., fire, EMS, SAR, arson, HAZMAT); may change or overlap as incident changes, as where fire becomes arson investigation once danger is over, or Motor Vehicle Accident becomes police business after vehicle extrication, fire, and HAZMAT issues are complete.

**Automatic aid:** An agreement between nearby fire department to assist each other during emergencies by responding with available manpower and apparatus. Dispatch will page assisting department at the same time as the AHJ. Resources that respond are outlined in the agreement.

**Available flow:** total amount of water that can be put on a fire, depending upon water supply, pump size, hoses, and distance to the fire. IC must assess available flow to determine whether additional apparatus or streams are required.

**Backdraft:** A fire phenomenon caused when heat and heavy smoke (unburned fuel particles) accumulate inside a compartment, depleting the available air, and then oxygen/air is re-introduced, completing the *fire triangle* and causing rapid combustion.

**Backflow preventer:** Automatic valve used in hose accessories to ensure water flows only in one direction. Used in permanent fire department connections (FDC) to sprinklers and dry standpipes, as well as portable devices used in firefighting.

**Beam Raise:** The term used when raising a ladder using the beam of the ladder. This technique is used when tight quarters are encountered or overhead obstructions may pose a problem.

**Black Fire** - This term has only recently been officially recognized. This describes a situation where HEAVY, dense, black smoke is being emitted by a fire. This smoke will be of high velocity, turbulent, high volume and extremely dense. It will also be very hot. For all practical purposes this is a dense, superheated, cloud of fuel that is too rich to ignite. This smoke may be doing as much damage as fire. It can also be a sign of imminent flashover.

**Blowers:** See “Fan”.

**Boiling liquid expanding vapor explosion (BLEVE):** An explosion of a pressure tank containing an overheated material when the vapor expansion rate exceeds the pressure relief capacity (e.g., steam boiler or propane tank). If the contents are flammable, the rapidly released vapor may react in a secondary fuel-air explosion.

**Bone pile:** After checking by hand moving limbs and logs to an area inside the control line. Consider hot material can be missed or moved and rekindle bone pile.

**Bump Up method:** Each member completes a section of line unless bumped up by another member before completion.

**Burning out:** The act of setting a fire inside the control line to consume fuel between control line and fire perimeter.

**Captains Ladder:** Also called an Attic Ladder. A narrow collapsible ladder that can be used inside a building or structure to access attics and overhead areas.

**Chimney fire:** Fast and intense fire in a chimney flue in which accumulated creosote and other combustion byproducts ignite.

**Chunking and piling:** Allowing material to burn itself out in an area where escape is unlikely.

**Cockloft:** Structural space above ceiling and below rafters, often connecting adjacent occupancies and permitting fire to spread laterally, often unseen.

**Cold trailing:** Method to control party dead fire edge by inspecting and feeling with hands to detect and extinguish every live spot and lining any live edge

**Collapse Zone:** Any area that may be affected by the collapse of a structure. Generally regarded as being a radius 1 ½ times the height of the structure, but may be greater near bearing walls of bow-string trussed roofs, or around structures with high explosive potential. If sufficient collapse zones cannot be established, consider placing apparatus and personnel at the corner of buildings to minimize risk.

**Company Performance Task (CPT):** Task level drill designed to provide training and education on basic firefighting skills.

**Compressed Air Foam System (CAFS):** The process of introducing compressed air and foam combined with water to increase extinguishing capabilities, use less water, and reduce hose weight. Both Class A and Class B foams can be used. In all cases, a Smooth bore nozzle is utilized. DFRA’s CAFS equipped apparatus are equipped with “breakdown” nozzles for CAFS use.

**Cross lay:** Arrangement of hose on a pumper such that it can be quickly unloaded from either side of the apparatus; often pre-connected to a pump outlet and equipped with a suitable nozzle.

**Cup trench:** A trench cut to mineral soil below fuel on a slope or on control line to prevent rolling material from spreading fire to unburned fuel.

**Defensive Operations:** A fire ground strategy based on firefighter safety and the protection of exposures. The goal is to simply confine the fire to the building/area of origin. No aggressive interior firefighting operations take place in the defensive mode. All fire streams are operated onto the fire from the outside. This strategy is employed when a fire has advanced to the point where attack operations are too dangerous, and/or the fire is beyond the capabilities of on scene resources.

**Direct attack:** Structural setting. "Putting the wet stuff on the red stuff." A form of fire attack in which hoses are advanced to the fire inside a structure and hose streams directed at the burning materials.

**Direct Attack:** Wildland setting. Constructing fireline right to the fire perimeter. One foot in the black.

**Division:** ICS term. Divisions are established to divide an incident into physical or geographical areas of operation.

**Draft:** The process of pumping water from a source below the pump.

**DRD - Drag Rescue Device** - This is a strap, or webbing, that is integrated with the firefighter's turnout coat which allows for easier dragging. A, relatively, small strap protrudes, from under a flap, near the collar on the back of the fire coat. A rescuer can grab this strap and have a means to drag a fellow firefighter to safety. This is required on all new coats in NFPA 1971, 2007 edition.

**Engine Company:** Squad or company that staffs a fire engine (pumper) and carries out duties involving getting water to the fire.

**Enhanced 9-1-1:** Electronic system for automatic correlation of physical telephone lines with information about the location of the caller -- a useful tool for dispatchers when the caller has an emergency but cannot speak.

**Evacuation:** Removal of personnel from a dangerous area, in particular, a HAZMAT incident, burning building, or other emergency. Also refers to act of removing firefighters from a structure in danger of collapsing.

**Exhaust Opening:** The opening(s) used for removal of fire products. Note that this opening may be created by unplanned ventilation due to fire effects, civilians, or freelancing responders or it may be created as the result of tactical action. Remember that any location where flames and/or smoke is visible is an exhaust opening.

**Exposure:** Property near fire that may become involved by transfer of heat or burning material from main fire, typically by convection or radiation. Exposures may also be interior- i.e. an adjacent room. Exposures are designated according to their proximity to the designated "Alpha" side. See also: *Location designation*

**Extrication** - The systematic and safe freeing or removal of persons who are trapped or pinned. This can be accomplished by highly technical means or may be as easy as opening a locked door.

**Fan:** Fans are high capacity portable blower (either gas powered or electric) used as mechanical ventilation to direct the products of combustion toward or away from a specific location while introducing clean air into a structure.

**Fast attack:** A firefighting mode described in an initial radio report that indicates a decision to make an immediate attack on the fire with only the resources already on the fireground. Incoming units should be prepared to establish a water supply and pull additional lines, as well as control utilities, and provide fans, lighting, salvage covers, and ventilation.

**Fire flow:** The amount of water being pumped onto a fire.

**Fire Flow Calculation:** Needed Fire Flow (NFF) = [(Length x Width) ÷ 3] x Percentage of fire involvement. For additional floors involved in fire, multiply the answer times the number of floors involved. For exposures (both internal and external) add 25 for each exposure to arrive at the NFF.

**Fire point:** temperature at which materials give off flammable gases that will sustain fire, typically higher than *flash point*. This is generally the temperature at *flashover*.

**Fire proofing fuel:** Using water chemicals or dirt to reduce chance of igniting fuel outside of control line

**Fire tetrahedron:** The fire tetrahedron is based on the components of igniting or extinguishing a fire. Each component represents a property necessary to sustain fire: fuel, oxygen, heat, and chemical chain reaction. Extinguishment is based upon removing or hindering any one of these properties.

**Fire triangle:** Model for understanding the major components necessary for fire: heat, fuel and oxygen. See also *fire tetrahedron* for a more comprehensive model.

**Fire wall:** Building structure designed to delay horizontal spread of a fire from one area of a building to another; often regulated by *fire code* and required to have self-closing doors, and fireproof construction.

**Flammable range, limits:** The percentage mixture of fumes with air that will sustain fire; outside the limits the mixture is either too lean or too rich to burn.

**Flanking Attack:** Constructing line parallel along flank from an anchor point, may be direct or indirect. Distance from fire perimeter is dependent on fire intensity. Strips of fuel are burned out.

**Flash point:** Lowest temperature at which a material will emit vapor combustible in air mixture. Lower than *fire point* of same material.

**Flashover:** simultaneous ignition of combustible materials in a closed space, as when materials simultaneously reach their *fire point*; may also result in *rollover*.

**Flat Raise:** The term used when raising a ladder using the rungs of the ladder. (Sometimes called a rung raise) This is the most common type of ladder raise. The ladder is either heeled by another firefighter, or the wall of the structure if being raised by a single firefighter.

**Fly Section:** The section of an extension ladder that is raised or extended from the base section, or from another fly section. A 35' ladder has 2 fly sections and one base section. The fly section is narrower than the base.

#### **Foam-Class A and B:**

**Forcible entry:** gaining entry to an area using force to disable or bypass security devices, typically using force tools, sometimes using tools specialized for entry (e.g., Halligan, K-tool).

**Forward lay:** Procedure of stringing water supply hose from a water source toward a fire scene; compare with *reverse lay*.

**Freelancing:** Describes a dangerous situation at an incident where an individual carries out tasks alone or without being assigned. Also may be violation of personnel accountability procedures.

**Friction loss:** Reduction of flow in a fire hose caused by friction between the water and the lining of the hose. Depends primarily upon diameter, type and length of hose, and amount of water (GPM) flowing through.

**Frontage:** The size of a building facing a street.

**Fully involved:** An element of *size-up* that means fire, heat, and smoke inside of a structure are so widespread that internal access must wait until fire streams can be applied. This is often confused with "well involved", and in either case a percentage of involvement is more helpful in determining the course of firefighting actions.

**Grease fire:** A fire involving any manner of cooking oil or other flammable cooking or lubricating materials.

**Group:** ICS term. Groups are established to divide the incident into functional areas of operation.

**Halligan** - An all-purpose steel prying bar used as a forcible entry tool. It looks like a adze with a point on the side. The story is that it was invented by a New York City firefighter named Huey Halligan. In some circles it is known as a "Pro Tool". Often this tool is married together with an ax. Together with possibly some other forcible entry tools, this is often referred to as "Irons".

**Halyard:** The rope or cable used to extend the fly section of an extension ladder.

**Hazard:** a source of danger of personal injury or property damage; fire hazard refers to conditions that may result in fire or explosion, or may increase spread of an accidental fire, or prevent escape from fire. Under worker safety and health regulations, employers have a general duty to provide a workplace free of hazards. See also fire prevention, and HAZMAT.

**HAZMAT:** Hazardous materials, including solids, liquids, or gasses that may cause injury, death, or damage if released or triggered.

**Hose pack:** A shoulder load of 100' of 1 ¾" hose with a nozzle.

**Hot spotting:** Checking the spread of fire at points of more rapid spread or special threat.

**Hot zone:** contaminated area of HAZMAT incident that must be isolated; requires suitable protective equipment to enter and decontamination upon exit; minimum hot zone distance from unknown material with unknown release is 330 feet (United Nations Emergency Response Guidebook); surrounded by "warm zone" where decontamination takes place.

**IDLH:** Any situation deemed Immediately Dangerous to Life and Health. IDLH is more narrowly defined by OSHA as an area of maximum danger to firefighters.

**Incident Commander:** Upon arriving at an incident the higher ranking person will either assume command, maintain command as is, or reassign command to a third party.

The Incident Commander:

- Has overall incident management responsibility delegated by the appropriate jurisdictional authority.
- Develops the incident objectives to guide the incident planning process.
- Approves the Incident Action Plan and all requests pertaining to the ordering and releasing of incident resources.

In some situations or agencies, a lower ranking but more qualified person may be designated as the Incident Commander.

The Incident Commander performs **all** major ICS Command and General Staff responsibilities unless these functions are activated.

**Incident Safety Officer: Or Safety Officer (SO)** The SO monitors incident operations and advises the Incident Commander on all matters relating to operational safety, including the health and safety of emergency responder personnel. The ultimate responsibility for the safe conduct of incident management operations rests with the Incident Commander or Unified Command and supervisors at all levels of incident management. The SO is, in turn, responsible to the Incident Commander for the set of systems and procedures necessary to ensure ongoing assessment of hazardous environments, coordination of multiagency safety efforts, and implementation of measures to promote emergency responder safety, as well as the general safety of incident operations. The SO has emergency authority to stop and/or prevent unsafe acts during incident operations. In a Unified Command structure, a single SO should be designated, in spite of the fact that multiple jurisdictions and/or functional agencies may be involved. The SO must also ensure the coordination of safety management functions and issues across jurisdictions, across functional agencies, and with private-sector and nongovernmental organizations.

**Indirect attack:** Structural setting. Method of firefighting in which water is pumped onto materials above or near the fire so that the splash rains onto the fire. Often used where a structure is unsafe to enter.

**Indirect Attack:** Wildland setting. Constructing fireline some distance from the fire perimeter. Use available natural or constructed barrier in construction. Ensure sufficient time to complete line and possibly burn out.

**Initial attack:** First point of attack on a fire where hose lines or fuel separation are used to prevent further extension of the fire.

**Inlet Opening:** The opening(s) used to introduce fresh air into the compartment. As with exhaust openings, inlet openings may be unplanned or planned. Openings may serve simply as an inlet or may serve as both an inlet and outlet with fire products exiting at the top and air entering at the bottom (bi-directional air track).

**Interface zone (also Wildland/structural interface or urban/wildland interface):** The zone where wildfires threaten structures or structural fires threaten wild lands, such as in residential areas adjacent to forests. This requires both wildland firefighting and structural firefighting in the same location, which involve very different tactics and equipment.

**ISO Rating:** (Insurance Services Office Fire Insurance Rating) A rating published by the Insurance Services Office. Insurance companies use this number to determine homeowner insurance premiums.

**Ladder Company:** A group of Firefighters, Officers and Engineers that staff a ladder truck.

**Location Designation (A-B-C-D sides, Alpha, Bravo, Charlie, Delta):** ICS uses a standard system to identify parts of a building or a fire scene. The exterior sides of a building are generally known as Sides A, B, C, and D. The front of the building is side A, with Sides B, C, and D following in a clockwise direction around the building. They may also be declared as Alpha, Bravo, Charlie, and Delta.

**Master stream:** A master stream is a heavy caliber stream delivered through a master stream water delivery appliance. A master stream is used when flows surpass 350 GPM becoming too difficult to be delivered from a handline operation due to nozzle reaction. **Means of egress:** The way out of a building during an emergency; may be by door, window, hallway, or exterior fire escape; local fire codes will often dictate the size, location and type according to the number of occupants and the type of occupancy.

**Mutual aid:** An agreement between nearby fire departments to assist each other during emergencies by responding with available manpower and apparatus. Requesting agency will ask for desired resource to respond.

**Natural Ventilation:** Use of pressure and density differences generated by the higher temperature of gases inside the compartment than outside and ambient wind conditions to accomplish the exchange of hot fire products and air.

**NFPA:** The National Fire Protection Association, which sets a number of standards for firefighting, equipment, and fire protection in the United States, and also adopted in many other countries.

**NIMS - The National Incident Management System** is a federally mandated program for the standardizing of command terminology and procedures. This standardizes communications between fire departments and other agencies. It is based upon simple terms that will be used nationwide.

**NIOSH:** National Institute for Occupational Safety and Health. A U.S. agency that is responsible for investigation of workplace deaths, including firefighters.

**Nozzle Pattern:** The form of the water or water/foam/air combination as it is discharged from a nozzle. Each type of nozzle (smooth bore or adjustable) produces different types of patterns for different extinguishing requirements.

**Nozzle pressure:** Pressure in a fire hose measured at the nozzle.

**Nozzle reaction:** The force felt when water is pumped through a nozzle.

**Occupancy:** Zoning and safety code term used to determine how a structure is permitted to be used and occupied, which in turn dictates the necessary safety structures and procedures.

**Occupancy class:** General categories of structures for purpose of safety planning, such as for hospital, assembly, industrial, single-family dwelling, apartment building, commercial, etc. They are further broken down by types of hazards associated with particular occupancies, such as gas stations.

**Offensive attack:** Method of firefighting in which water or other extinguisher is taken directly to the seat of the fire, as opposed to being pumped in that general direction from a safe distance.

**One lick progressive method:** Each member does one to several licks and moves forward a specific distance with others following and filling in between. The distance is determined by the number of members, tool order and number of licks to complete the work for that tool.

**OSHA:** Occupational Safety & Health Administration. U.S. government agency concerned with regulating employee safety, particularly in hazardous occupations such as firefighting.

**Overhaul:** Late stage in fire-suppression process during which the burned area is carefully examined for remaining sources of heat that may *re-kindle* the fire. Often coincides with *salvage* operations to prevent further loss to structure or its contents, as well as fire-cause determination and preservation of evidence.

**Oxidizer:** A hazardous material containing oxygen that can combine with adjacent fuel to feed a fire.

**Personal alert safety system (PASS):**

**Personal Protective Equipment (PPE):** Personal protective equipment consisting of SCBA, Helmet, Protective nomex hood, Protective coat and thermal liner, Protective trousers and thermal liner, Protective boots, Gloves, Eye protection, Hearing protection, or any other hazard specific piece of equipment.

**Portable Standpipe:** A term used to describe a length of 2 ½" hose that is extended into a building or raised to a floor or roof and then used to supply a hose pack.

**Positive Pressure Attack (PPA):** This term was coined by Garcia, Kauffmann, & Schelble (2006) to differentiate positive pressure ventilation initiated prior to fire attack from use of this tactic following fire control operations. From a physics perspective, PPV and PPA are the same, the term PPA simply designates the sequence in which the tactic is performed.

**Positive Pressure Ventilation (PPV):** Use of a fan at the inlet opening to increase the pressure differential between the inlet and exhaust opening to control and increase the exchange of fire products and air.

**Pre-Connect:** Hand lines (1 ¾" or 2 ½") connected to the plumbing on an Engine, Ladder, or Tanker. Will be 200' long when in a hose bed, or 100' if in a tray in the front bumper.

**Pre-fire, pre-incident planning:** Information collected by fire prevention officers to assist in identifying hazards and the equipment, supplies, personnel, skills, and procedures needed to deal with a potential incident.

**Pre-planning:** Fire protection strategy involving visits to potentially hazardous occupancies for inspection, follow up analysis and recommendations for actions to be taken in case of specific incidents.

**Primary Search** - Very early in any fire or hazardous environment search or rescue Command will call for a "Primary Search". This is a quick search of all compartments in a structure for victims. The crews involved in the search should report, "*Primary Search, All Clear.*"

**Radiant Heat Zone:** An area on a fire scene where a fire apparatus may become an exposure if the fire is not controlled quickly enough.

**Radio Report:** A clear, plain language description of conditions, actions, and needs.

**Recovery:** Location and removal of deceased victims. Also, the time needed for a firefighter to spend in *rehab* before being considered ready to continue working the incident.

**Rehab, Rehabilitation: 1)** The act of recovering from strenuous activity. **2)** A group on an emergency scene whose function is to facilitate recovery from strenuous activity.

**Rescue:** The act of locating and extricating viable victims on an emergency scene.

**Roof Ladder:** A straight ladder equipped with retractable hooks so that the ladder can be secured to the peak of a pitched roof. The ladder then lies flat against the surface, providing secure footing for the firefighters. DFRA owns both 14' and 16' lengths.

**Rung Raise:** The term used when raising a ladder using the rungs of the ladder. (Sometimes called a flat raise) This is the most common type of ladder raise. The ladder is either heeled by another firefighter, or the wall of the structure if being raised by a single firefighter.

**Salvage** - The procedure whereby property is protected or saved. This can commence at the same time as firefighting or it can occur later. Salvage operations often include the covering of furnishings with tarps known as "Salvage Covers" or it can be as simple as placing a pan under a water drip to protect the apartment below.

**Scratch line:** Expedient method for a fuel break in light fuels until a wider line can be constructed

**Secondary Search** - Once the fire is under control a second search of the structure will be conducted. The searching companies should report, "*Secondary Search, All Clear.*"

**Siamese** - A device which is used to combine two lines into one. (Not to be confused with a "wye", which splits one line into two.)

**Size up** - This is the procedure and the report of the situation. The first arriving officer on the scene will "give a size-up" over the radio. This will include a description of the structure and the initial plan of attack. It's been said that size-up starts even before you leave the station. The time of day, the weather conditions, the availability of water and what you may already know about this structure are examples of factors that go into size-up. Once you arrive you don't just look at the fire. Are there cars in the driveway? Are there toys in the yard? Are the newspapers piled up? Many things go into size-up.

**Smoke explosion:** See *backdraft*.

**Soften:** The process of removing barriers to entry and egress. Forcing doors (and then re-closing) and removing bars from windows are examples of softening a building.

**Solid stream:** fire stream from round orifice of *nozzle*. Compare *straight stream*.

**Staging:** **Level 1** staging occurs in close proximity to emergency scene by initial arriving units- usually down the block or adjacent to a hydrant while awaiting instructions. **Level 2** staging is a remote location capable of handling large amounts of resources awaiting an assignment on the emergency scene.

**Standard operating procedure:** Rules for the operation of a fire department, such as how to respond to various types of emergencies, training requirements, use of protective equipment, radio procedures; often include local interpretations of regulations and standards.

**Standpipe Bag:** A bag containing a gated wye, short section of 2 ½" hose, and tools used to connect to a standpipe.

**Standpipe Operations:** The process of connecting to, and pumping through, a fixed plumbing system within a structure. Hose packs will be connected to the system utilizing components in the Standpipe Bag. Pump pressures depend on line selection, length, and number of floors (elevation gain or loss). An additional 25% may be added for system loss.

**Static pressure:** The pressure in a water system when the water is not flowing.

**Straight stream:** Round, hollow stream formed as water passes a round baffle through a round orifice (e.g., on an adjustable *nozzle*.) Compare *solid stream*.

**Stretch:** The command to pull, connect, and deploy fire hose and a nozzle.

**Tactical Ventilation:** Planned, systematic, and coordinated removal of heat, smoke, and fire gases and their replacement with fresh air. There are three important parts of this definition, 1) tactical ventilation is part of the overall tactical plan and is coordinated with other fireground operations (particularly fire control), 2) fire products are removed, and 3) fresh (cooler) air is introduced into the compartment.

**Thermal Imaging Camera (TIC):** A type of thermo graphic camera used in Firefighting. It sends infrared radiation as visible light. Such Camera's allow Firefighters to see areas of heat through smoke darkness, or heat permeable barriers. TIC's are typically hand held but may be helmet mounted. They are constructed of heat and water resistant material to withstand fire ground operations. Tic's can be used for locating heat sources and also to help locate down or lost Firefighters.

**Two-in, two-out (or "two in/two out"):** Refers to the standard safety tactic of having one team of two firefighters enter a hazardous zone (*IDLH*), while at least two others stand by outside in case the first two need rescue — thus requiring a minimum of four firefighters on scene prior to starting interior attack. Also refers to the "buddy system" in which firefighters never enter or leave a burning structure alone.

**Type I, II, III, IV, V Building:** U.S. classification system for fire resistance of building construction types, including definitions for "resistive" Type I, "non-combustible" Type II, "ordinary" Type III, heavy timber Type IV, and "frame construction" Type V (i.e., made entirely of wood).

**Universal precautions:** The use of safety barriers (gloves, mask, goggles) to limit an emergency responder's contact with contaminants, especially fluids of injured patients.

**Vapor suppression:** Process of reducing the amount of flammable or other hazardous vapors, from a flammable liquid, mixing with air, typically by careful application of a foam blanket on top of a pool of material

**VOIDS (building):** Also Void space. Enclosed portions of a building where fire can spread undetected.

**Water hammer:** Large, damaging shock wave in a water supply system caused by shutting a valve quickly or by permitting a vehicle to drive across an unprotected fire hose.

**Working fire:** A term which describes a fire in progress in a structure that may be a room and contents fire, or one that has evolved into a structure fire.

**Wye (Y)** - A device for splitting one hose into two (usually) smaller lines. (Not to be confused with a "Siamese" which is used to combine two lines into one.)

**Zone:** Section of structure indicated on *fire alarm control panel* where sensor was activated.